

CM-SRS.M1 / CM SRS.M2

(D) Betriebs- und Montageanleitung

Einphasige Stromüberwachungsrelais, CM Reihe

Hinweis: Diese Betriebs- und Montageanleitung enthält nicht sämtliche Detailinformationen zu allen Typen der Produktreihe und kann auch nicht jeden Einsatzfall der Produkte berücksichtigen. Alle Angaben dienen ausschließlich der Produktbeschreibung und sind nicht als zugesicherte Eigenschaften im Rechtssinne aufzufassen. Weiterführende Informationen und Daten erhalten Sie in den Katalogen und Datenblättern der Produkte, über die örtliche ABB-Niederlassung sowie auf der ABB Homepage unter <http://www.abb.com>. Technische Änderungen jederzeit vorbehalten. In Zweifelsfällen gilt der deutsche Text.

Nur von einer entsprechend qualifizierten Fachkraft zu installieren. Dabei landesspezifische Vorschriften (z.B. VDE, etc.) beachten. Vor der Installation diese Betriebs- und Montageanleitung sorgfältig lesen und beachten. Die Geräte sind wartungsfreie Einbaugeräte.



(GB) Operating and installation instructions

Single-phase current monitoring relays, CM range

Note: These operating and installation instructions cannot claim to contain all detailed information of all types of this product range and can even not consider every possible application of the products. All statements serve exclusively to describe the product and have not to be understood as assured characteristics with legal force. Further information and data is obtainable from the catalogues and data sheets of this product, from the local ABB sales organisations as well as on the ABB homepage <http://www.abb.com>. Subject to change without prior notice. The German text applies in cases of doubt.

The device must be installed by qualified persons only and in accordance with the specific national regulations (e.g., VDE, etc.). Before installing this unit, read these operating and installation instructions carefully and completely. The devices are maintenance-free chassis-mounted units.



(F) Instructions de service et de montage

Contrôleurs de courant monophasée, gamme CM

Note: Ces instructions de service et de montage ne contiennent pas toutes les informations relatives à tous les types de cette gamme de produits et ne peuvent pas non plus tenir compte de tous les cas d'application. Toutes les indications ne sont données qu'à titre de description du produit et ne constituent aucunes obligations légales. Pour de plus amples informations, veuillez-vous référer aux catalogues et aux fiches techniques des produits, à votre agence ABB ou à notre site <http://www.abb.com>. Sous réserve de modifications techniques. En cas de divergences, le texte allemand fait foi.

L'installation de ces produits doit être réalisée uniquement par une personne compétente et en conformité avec les prescriptions nationales (p.e. VDE, etc.). Avant l'installation de cet appareil veuillez lire l'intégralité de ces instructions. Ces produits sont des appareils encliquetables qui ne nécessitent pas d'entretien.



(E) Instrucciones de servicio y de montaje

Relé de control de intensidad monofásica, serie CM

Nota: Estas instrucciones no contienen todas las informaciones detalladas relativas a todos los tipos del producto ni pueden considerar todos los casos de operación. Todas las indicaciones son a título descriptivo del producto y no constituyen obligaciones legales. Para más información, consulte los catálogos, las hojas de características, la sucursal local de ABB o la Web <http://www.abb.com>. Sujeto a cambios técnicos sin previo aviso. En caso de duda, prevalece el texto alemán.

La instalación debe llevarse a cabo sólo por personal especializado. Es necesario respetar las normas específicas del país (p.ej. VDE, etc.). Antes de la instalación lea completamente estas instrucciones. Estos aparatos son equipos para su montaje en conjuntos y son de libre mantenimiento.



(I) Istruzioni per l'uso ed il montaggio

Relè di controllo di corrente monofase, serie CM

Nota: Le presenti istruzioni per l'uso ed il montaggio non contengono tutte le informazioni di dettaglio sull'intera gamma di prodotti e non possono trattare tutti i casi applicativi. Tutte le indicazioni servono esclusivamente a descrivere il prodotto e non sono da interpretare come caratteristiche garantite con valore di legge. Per ulteriori informazioni consultare i cataloghi ed i data sheet dei prodotti, o la nostra homepage <http://www.abb.com>, oppure rivolgersi alla filiale locale di ABB. Ci riserviamo il diritto di effettuare eventuali modifiche tecniche. In caso di discrepanze o fraintendimenti fa fede il testo in lingua tedesca.

Installazione solo a cura di personale specializzato. Bisogna osservare le specifiche norme nazionali (p.e. VDE, etc.). Prima dell'installazione leggere attentamente le seguenti istruzioni. Questi prodotti sono apparecchi ad incasso, che non hanno bisogno di manutenzione.



(RU) Инструкция по установке и эксплуатации

Однофазное реле контроля тока, серия CM

Примечание: Настоящая инструкция по установке и эксплуатации не претендует на полноту содержащейся здесь информации по всем типам серии настоящего изделия и даже не рассматривает все возможности применения настоящего изделия. Вся информация служит исключительно для его описания и не должна рассматриваться в качестве гарантированных характеристик, имеющих юридическую силу. Дополнительную информацию и данные можно получить из каталогов и Листов данных на настоящее изделие в местном представительстве компании ABB, а также на сайте компании ABB по адресу: <http://www.abb.com>. Возможны изменения без предварительного уведомления. При возникновении сомнений текст на немецком языке имеет приоритет.

Устройство подлежит установке только квалифицированным персоналом в соответствии с национальными требованиями (например, VDE и т.д.). Перед началом установки данного изделия полностью и внимательно прочитайте инструкцию по установке. Устройство устанавливается на шасси и не требует обслуживания.



(CN) 操作指南

CM 系列单相电流监视器

注意：本操作指南不包含技术数据和全部应用说明，所有数据指示具有对产品特性进行说明的作用，因此不具备法律效应。详细说明请参阅技术样本或联络 ABB 当地办事处或浏览 ABB 网站 (<http://www.abb.com>)。如有更改，恕不通知。并以德文为标准。

器件必须由专业人员按照国际专业规章安装（如 VDE）。安装前，请先详细阅读本安装指南。产品底座不含任何需要安装的部分，请不要打开底座。此产品为免维护底板安装器件。



ADDITIONAL INFORMATION RELATING TO UL APPROVALS:
Only for use in Pollution Degree 2 Environment

- (D) Produkt anbringen
- (GB) Fix product
- (F) Montage du produit
- (E) Fijar el producto
- (I) Montare il prodotto
- (RU) Установка устройства
- (CN) 产品安装

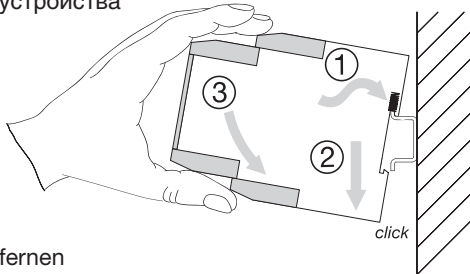

- (D) Produkt entfernen
- (GB) Remove product
- (F) D montage du produit
- (E) Desmontar el producto
- (I) Rimuovere il prodotto
- (RU) Демонтаж устройства
- (CN) 产品卸装

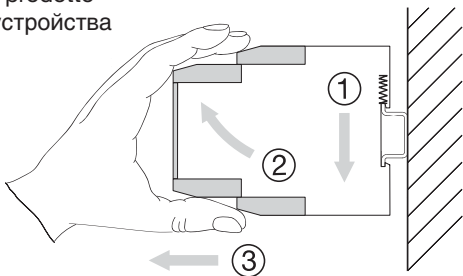

- (D) Plombierbare Klarsichtabdeckung anbringen
- (GB) Fix sealable transparent cover
- (F) Fixation du capot transparent condamnable
- (E) Fijar cubierta transparente sellable
- (I) Fissare la copertura trasparente sigillabile
- (RU) Установка печатаваемой прозрачной крышки
- (CN) 密封透明盖的安装

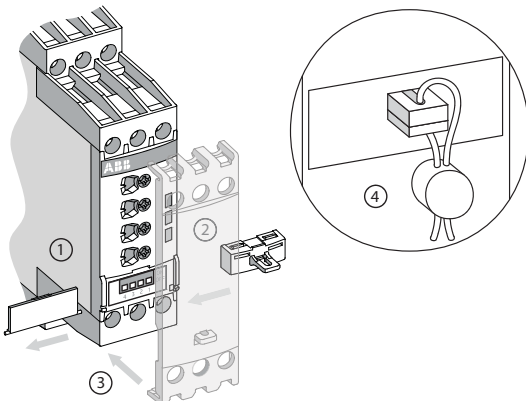

(D)	Schraubklemmen	Push-in Klemmen
(GB)	Screw terminals	Push-in terminals
(F)	Bornes � vis	Bornes ressort � connection rapide
(E)	Terminales de mordaza	Terminales de resorte
(I)	Morsetti a vite	Morsetti Push-in
(RU)	Винтовые клеммы	Вставные клеммы
(CN)	螺钉连接端子	插入式连接端子

DIN ISO 2380-1 Form A 0.8 x 4 mm (0.0315 x 0.157") DIN ISO 8764-1 PZ 1 � 4.5 mm (0.177")		0.6-0.8 Nm (5.31-7.08 lb.in)	
		1 x 0.5-2.5 mm ² 2 x 0.5-1.5 mm ² (1 x 20-14 AWG 2 x 20-16 AWG)	2 x 0.5-1.5 mm ² (2 x 20-16 AWG)
		1 x 0.5-4 mm ² 2 x 0.5-2.5 mm ² (1 x 20-12 AWG 2 x 20-14 AWG)	2 x 0.5-1.5 mm ² (2 x 20-16 AWG)
		1 x 0.5-2.5 mm ² 2 x 0.5-1.5 mm ² (1 x 20-14 AWG 2 x 20-16 AWG)	2 x 0.5-1.5 mm ² (2 x 20-16 AWG)
DIN 46228-1-A DIN 46228-4-E			

CONNECT (IN)

DISCONNECT (OUT)

2CDC 252 001 F0011

2CDC 253 007 F0011

2CDC 253 006 F0010

2CDC 253 007 F0010

2CDC 253 028 F0011

I

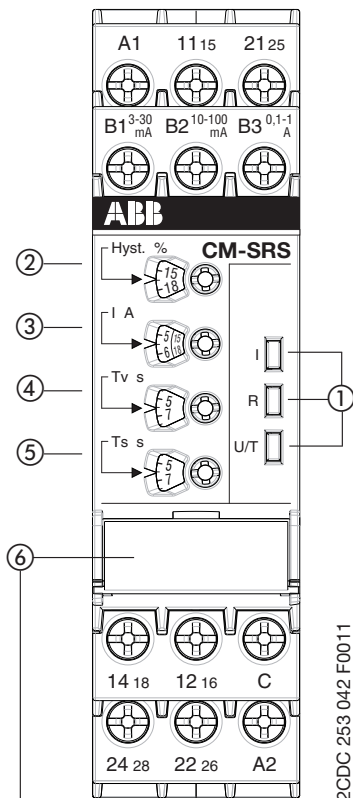

2CDC 253 042 F0011

II

Position	4	3	2	1
ON ↑				
OFF				

2CDC 252 273 F0005

III

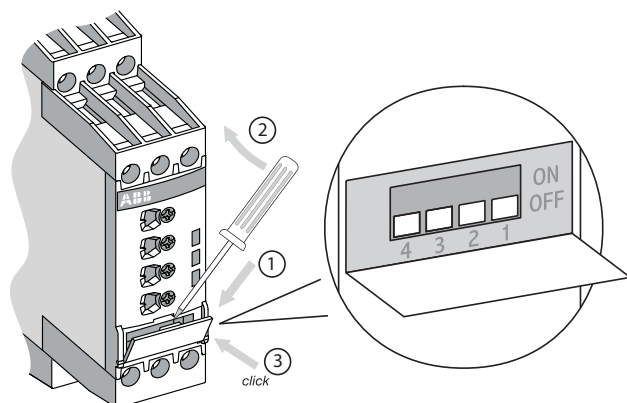

2CDC 253 030 F0011

IV

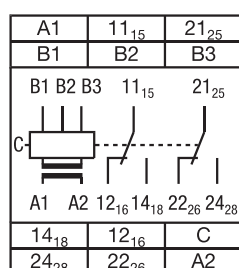

2CDC 252 205 F0005

I Frontansicht mit Bedienelementen

- ① Betriebszustandsanzeige mit LEDs
 - I: LED rot - Anzeige des Messstroms
 Schalterstellung -
 Überstrom
 Schalterstellung -
 Unterstrom
 - R: LED gelb - Anzeige der Schaltstellung der Ausgangsrelais
 angezogen
 angezogen, abgefallen,
 - U/T: LED grün - Anzeige Speisespannung und Zeitablauf
 Speisespannung liegt an
 Einschaltverzögerung T_S aktiv
 Auslöseverzögerung T_V aktiv
- ② Einstellung der Rückschaltsschwelle (Hysterese)
- ③ Einstellung des Schwellwertes
- ④ Einstellung der Auslöseverzögerung T_V (0 s; 0,1-30 s)
- ⑤ Einstellung der Einschaltverzögerung T_S (0 s; 0,1-30 s)

II DIP-Schalterstellungen

- ⑥ DIP-Schalter zur Einstellung von:
 - 1 ON = Unterstromüberwachung
OFF = Überstromüberwachung
 - 2 ON = Ruhestromprinzip
OFF = Arbeitsstromprinzip
 - 3 ON = Speicherung ein
OFF = Speicherung aus
 - 4 Keine Funktion

Auslieferungszustand:
Alle DIP-Schalter in Position OFF

III DIP-Schalterposition













IV Anschlussdiagramm

- A1-A2 Speisespannung U_S
- B-C Messstrom
- 11(15)-12(16)/14(18) Ausgangsrelais 1
- 21(25)-22(26)/24(28) Ausgangsrelais 2

	Messbereich
CM-SRS.M1	B1-C 3-30 mA
	B2-C 10-100 mA
	B3-C 0,1-1 A
CM-SRS.M2	B1-C 0,3-1,5 A
	B2-C 1-5 A
	B3-C 3-15 A ¹⁾

¹⁾ Bei Messströmen > 10 A ist ein seitlicher Abstand von 10 mm (0.39 in) erforderlich

I Front view with operating controls

- ① Indication of operational states with LEDs
- I: LED red - Status indication of the measured current
- Switch position  -
 overcurrent
- Switch position  -
 undercurrent
- R: LED yellow - Status indication of the output relays
-  energized
-  energized, 
-  de-energized, 
- U/T: LED green - Status indication of control supply voltage and timing
-  Control supply voltage applied
-  start-up delay T_S active
-  tripping delay T_V active

- ② Adjustment of the release threshold (hysteresis)
- ③ Adjustment of the threshold value
- ④ Adjustment of the tripping delay T_V (0 s; 0,1-30 s)
- ⑤ Adjustment of the start-up delay T_S (0 s; 0,1-30 s)

II DIP switch functions

- ⑥ DIP switches for the adjustment of:
- ON = Undercurrent monitoring
OFF = Overcurrent monitoring
 - ON = Closed-circuit principle
OFF = Open-circuit principle
 - ON = Latching function ON
OFF = Latching function OFF
 - No function

Default setting:
All DIP switches in position OFF

III DIP switch position













IV Connection diagram

A1-A2	Control supply voltage U_s
B-C	Measured current
11(15)-12(16)/14(18)	Output relay 1
21(25)-22(26)/24(28)	Output relay 2

	Measuring range	
CM-SRS.M1	B1-C	3-30 mA
	B2-C	10-100 mA
	B3-C	0,1-1 A
CM-SRS.M2	B1-C	0,3-1,5 A
	B2-C	1-5 A
	B3-C	3-15 A ¹⁾

¹⁾ In case of measured currents > 10 A, lateral spacing has to be min. 10 mm (0.39 in)

I Face avant et dispositifs de commande

- ① Indication de fonctionnement par LED
- I: LED rouge - Indication du courant de mesure
- Position de l'interrupteur  -
 surintensité
- Position de l'interrupteur  -
 sous-intensité
- R: LED jaune - Indication de l'état des relais de sortie
-  activés
-  activés, 
-  désactivés, 
- U/T: LED verte - Indication de la tension d'alimentation de commande et temporisation
-  tension d'alimentation de commande appliquée
-  temporisation de démarrage T_S active
-  temporisation de déclenchement T_V active

- ② Réglage de l'hystérésis
- ③ Réglage de la valeur de seuil
- ④ Réglage de la temporisation de déclenchement T_V (0 s; 0,1-30 s)
- ⑤ Réglage de la temporisation de démarrage T_S (0 s; 0,1-30 s)

II Fonctions des micro-interrupteurs

- ⑥ Micro-interrupteurs pour le réglage de:
- ON = Contrôle de sous-intensité
OFF = Contrôle de surintensité
 - ON = Fonctionnement en logique négative
OFF = Fonctionnement en logique positive
 - ON = Mémorisation activée
OFF = Sans mémorisation
 - Pas de fonction

Etat de livraison:
Tous les micro-interrupteurs en position OFF

III Position des micro-interrupteurs













IV Schéma de connexion

A1-A2	Tension d'alimentation de commande U_s
B-C	Courant de mesure
11(15)-12(16)/14(18)	Relais de sortie 1
21(25)-22(26)/24(28)	Relais de sortie 2

	Gamme de mesure	
CM-SRS.M1	B1-C	3-30 mA
	B2-C	10-100 mA
	B3-C	0,1-1 A
CM-SRS.M2	B1-C	0,3-1,5 A
	B2-C	1-5 A
	B3-C	3-15 A ¹⁾

¹⁾ Dans le cas de courants de mesure supérieurs à 10 A, l'espace latérale doit être de 10 mm (0.39 in) au minimum

I Vista frontal con elementos de mando

- ① Indicadores de servicio con LEDs
- I: LED rojo - Indicación de la corriente de medida
- Posición interruptor  -
 sobrecorriente
- Posición interruptor  -
 subintensidad
- R: LED amarillo - Indicación del estado de los relés de salida
-  energizados
 energizados, 
 des-energizados, 
- U/T: LED verde - Indicación tensión de alimentación de mando y temporización
-  tensión de alimentación de mando aplicada
 retardo de arranque T_S activado
 retardo de disparo T_V activado
- ② Ajuste del histéresis
- ③ Ajuste del valor umbral
- ④ Ajuste del retardo de disparo T_V (0 s; 0,1-30 s)
- ⑤ Ajuste del retardo de arranque T_S (0 s; 0,1-30 s)

II Funciones de los interruptores DIP

- ⑥ Interruptores DIP para el ajuste de:
- ON = Control de subintensidad
OFF = Control de sobrecorriente
 - ON = Principio de circuito cerrado
OFF = Principio de circuito abierto
 - ON = Función de retención activada
OFF = Función de retención desactivada
 - Ninguna función

Entrega de fábrica:
 Todos los interruptores DIP en posición OFF

III Posición de los interruptores DIP













IV Esquema de conexión

A1-A2	Tensión de alimentación de mando U_s
B-C	Corriente de medida
11(15)-12(16)/14(18)	Relé de salida 1
21(25)-22(26)/24(28)	Relé de salida 2

	Rango de medida	
CM-SRS.M1	B1-C	3-30 mA
	B2-C	10-100 mA
	B3-C	0,1-1 A
CM-SRS.M2	B1-C	0,3-1,5 A
	B2-C	1-5 A
	B3-C	3-15 A ¹⁾

¹⁾ Para corrientes de medida > 10 A, dejar un espacio lateral como mínimo de 10 mm (0.39 in)

I Vista frontale con gli elementi di comando

- ① LED di visualizzazione dello stato di funzionamento
- I: LED rosso - Indicazione della corrente di misura
- Posizione interruttore  -
 sovracorrente
- Posizione interruttore  -
 sottocorrente
- R: LED giallo - Indicazione dello stato dei relé d'uscita
-  eccitati
 eccitati, 
 diseccitati, 
- U/T: LED verde - Indicazione tensione di comando e stato della temporizzazione
-  tensione di comando applicata
 ritardo di inserzione T_S attivo
 ritardo di intervento T_V attivo
- ② Impostazione della soglia di ripristino (isteresi)
- ③ Impostazione del valore di soglia
- ④ Impostazione del ritardo di intervento T_V (0 s; 0,1-30 s)
- ⑤ Impostazione del ritardo di inserzione T_S (0 s; 0,1-30 s)

II Funzioni degli interruttori DIP

- ⑥ Interruttori DIP per l'impostazione di:
- ON = Controllo di sottocorrente
OFF = Controllo di sovracorrente
 - ON = Funzionamento normalmente chiuso
OFF = Funzionamento normalmente aperto
 - ON = Memorizzazione ON
OFF = Memorizzazione OFF
 - Senza funzione

Impostazione di fabbrica:
 Tutti gli interruttori DIP in posizione OFF

III Posizione degli interruttori DIP













IV Schema di collegamento

A1-A2	Tensione di comando U_s
B-C	Corrente di misura
11(15)-12(16)/14(18)	Relè di uscita 1
21(25)-22(26)/24(28)	Relè di uscita 2

	Campo di misura	
CM-SRS.M1	B1-C	3-30 mA
	B2-C	10-100 mA
	B3-C	0,1-1 A
CM-SRS.M2	B1-C	0,3-1,5 A
	B2-C	1-5 A
	B3-C	3-15 A ¹⁾

¹⁾ Nel caso in cui la corrente di misura fosse > 10 A, lo spazio laterale deve essere min. 10 mm (0.39 in)

I Вид спереди на элементы управления

- ① Светодиоды для индикации состояния реле
- I: красный - Индикация состояния измеряемого тока
- Положение выключателя  -
 перегрузка по току
- Положение выключателя  -
 пониженный ток
- R: желтый - Индикация состояния выходного реле
-  под напряжением
 под напряжением, 
 обесточено, 
- U/T: зеленый - Индикация состояния питающего напряжения и отсчета времени
-  питание включено
 выдержка срабатывания реле T_s включена
 выдержка срабатывания реле T_v включена
- ② Регулировка порога расцепления (гистерезис)
- ③ Регулировка порогового значения
- ④ Регулировка выдержки срабатывания реле T_v (0 s; 0,1-30 s)
- ⑤ Регулировка выдержки включения реле T_s (0 s; 0,1-30 s)

II Функции DIP-переключателей

- ⑥ DIP-переключатели для настройки:
- ON = контроль пониженного тока
OFF = контроль перегрузки по току
 - ON = принцип замкнутой цепи
OFF = принцип разомкнутой цепи
 - ON = функция памяти ВКЛ.
OFF = функция памяти ВЫКЛ.
 - нет функций

Состояние поставки: ВСЕ DIP-переключатели установлены в положении ВЫКЛ.

III Положения DIP-переключателей













IV Схема соединений

A1-A2	Питающее напряжение U_s
B-C	Измеряемый ток
11(15)-12(16)/14(18)	Выходное реле 1
21(25)-22(26)/24(28)	Выходное реле 2

	Измеряемый диапазон
CM-SRS.M1	B1-C 3-30 mA
	B2-C 10-100 mA
	B3-C 0,1-1 A
CM-SRS.M2	B1-C 0,3-1,5 A
	B2-C 1-5 A
	B3-C 3-15 A ¹⁾

1) Если величина измеряемого тока > 10 A, то расстояние до других приборов должно быть не менее 10 мм

I 操作控制前面板

- ① LED 状态指示
- I: 红色 LED - 测量电流状态指示
 开关位置  -
 过电流
 开关位置  -
 欠电流
- R: 黄色 LED - 输出继电器动作状态指示
 动作
 动作, 
 复位, 
- U/T: 绿色 LED - 供电电压和计时状态指示
 供电电压上电
 起动延时 T_s 有效
 响应延时 T_v 有效
- ② 释放阈值 (迟滞) 调节
- ③ 阈值调节
- ④ 响应延时时间调节 T_v (0; 0.1-30 s)
- ⑤ 起动延时时间调节 T_s (0; 0.1-30 s)

II DIP 开关功能

- ⑥ DIP 开关调节如下:
- ON = 欠电流监视
OFF = 过电流监视
 - ON = 闭路原则
OFF = 开路原则
 - ON = 故障保持功能有效 ON
OFF = 故障保持功能无效 OFF
 - 无功能

运输过程中: 所有 DIP 开关均处于 OFF 位置

III DIP 开关位置

IV 接线图

- A1-A2 供电电压
- B1/B2/B3-C 测量电流
- 11(15)-12(16)/14(18) 输出继电器 1
- 21(25)-22(26)/24(28) 输出继电器 2

	测量范围
CM-SRS.M1	B1-C 3-30 mA
	B2-C 10-100 mA
	B3-C 0.1-1 A
CM-SRS.M2	B1-C 0.3-1.5 A
	B2-C 1-5 A
	B3-C 3-15 A ¹⁾

1) 如果测量电流 > 10A, 相邻侧面必须留有最少 10mm 空间

Function diagrams

V Overcurrent monitoring without latching

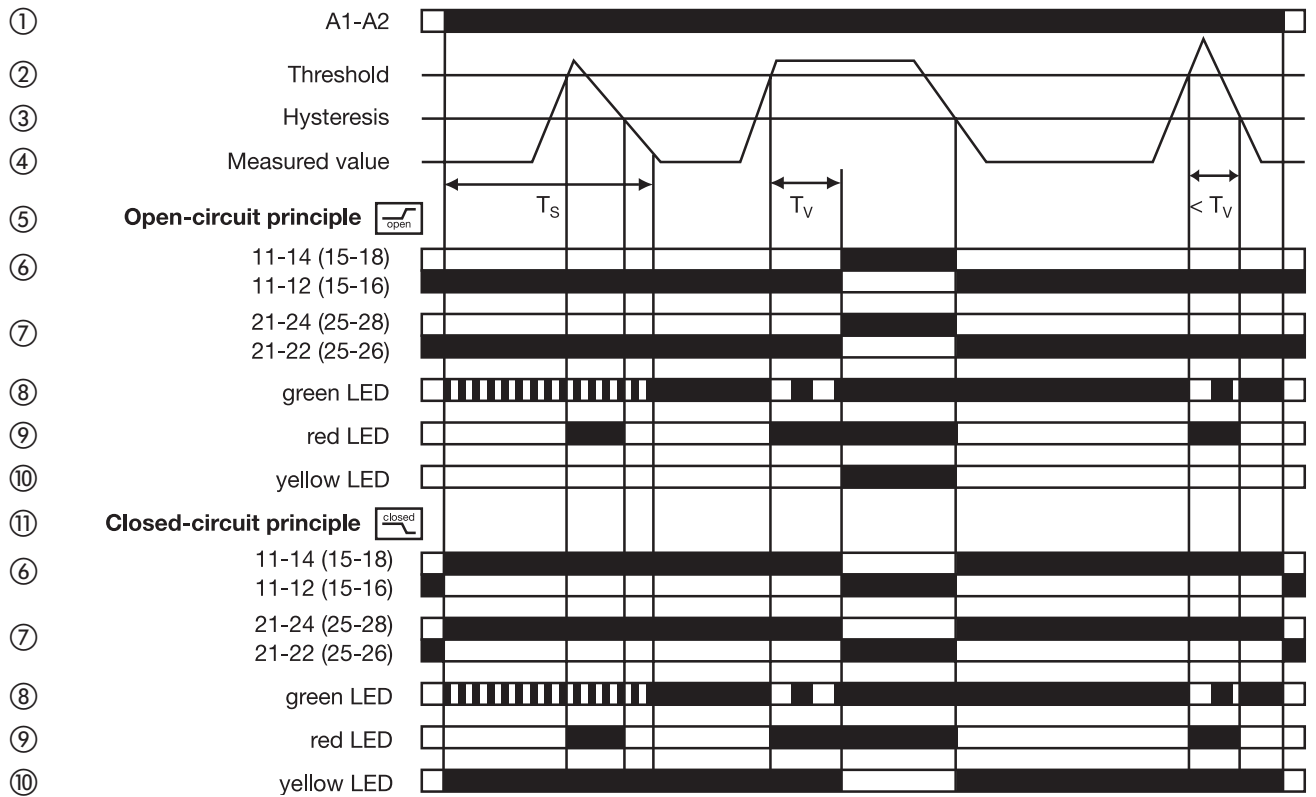

2CDC 252 212 F0205

VI Undercurrent monitoring without latching

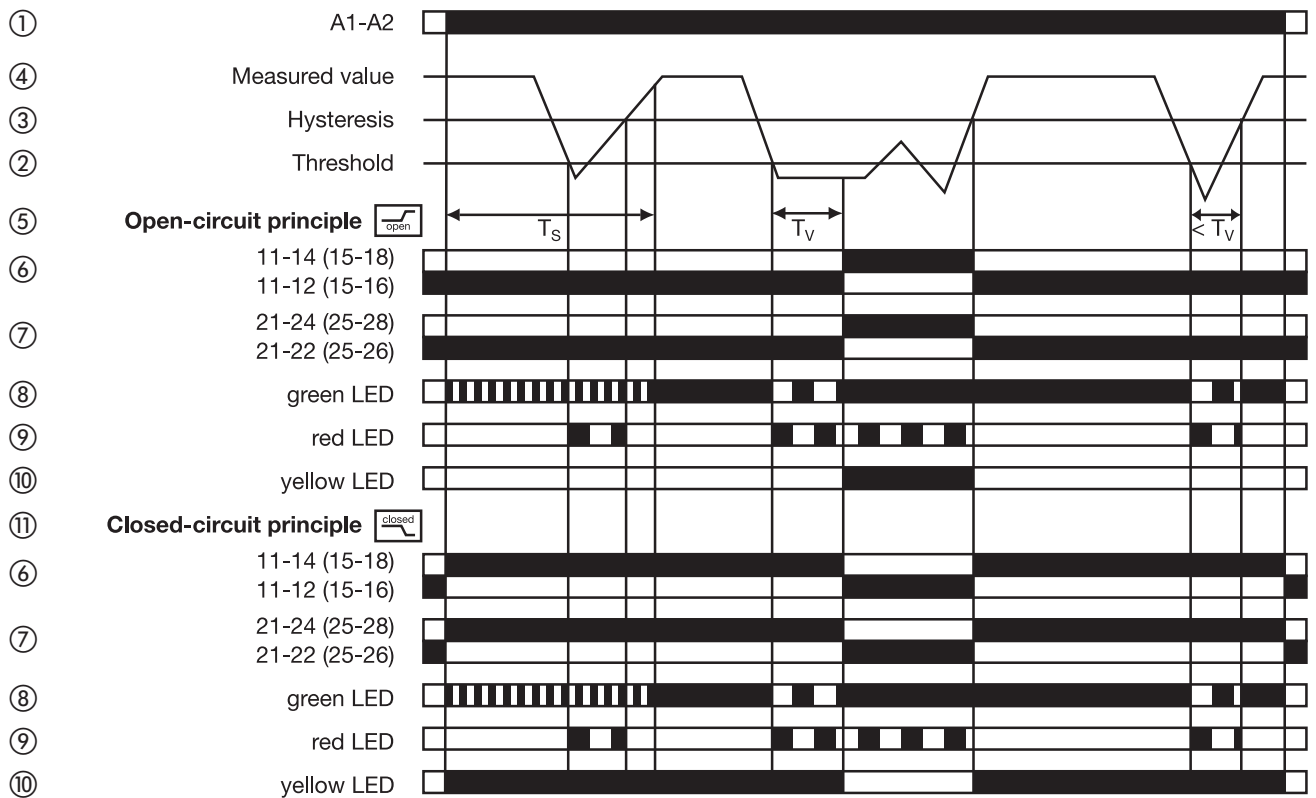

2CDC 252 213 F0205

VII Overcurrent monitoring with latching

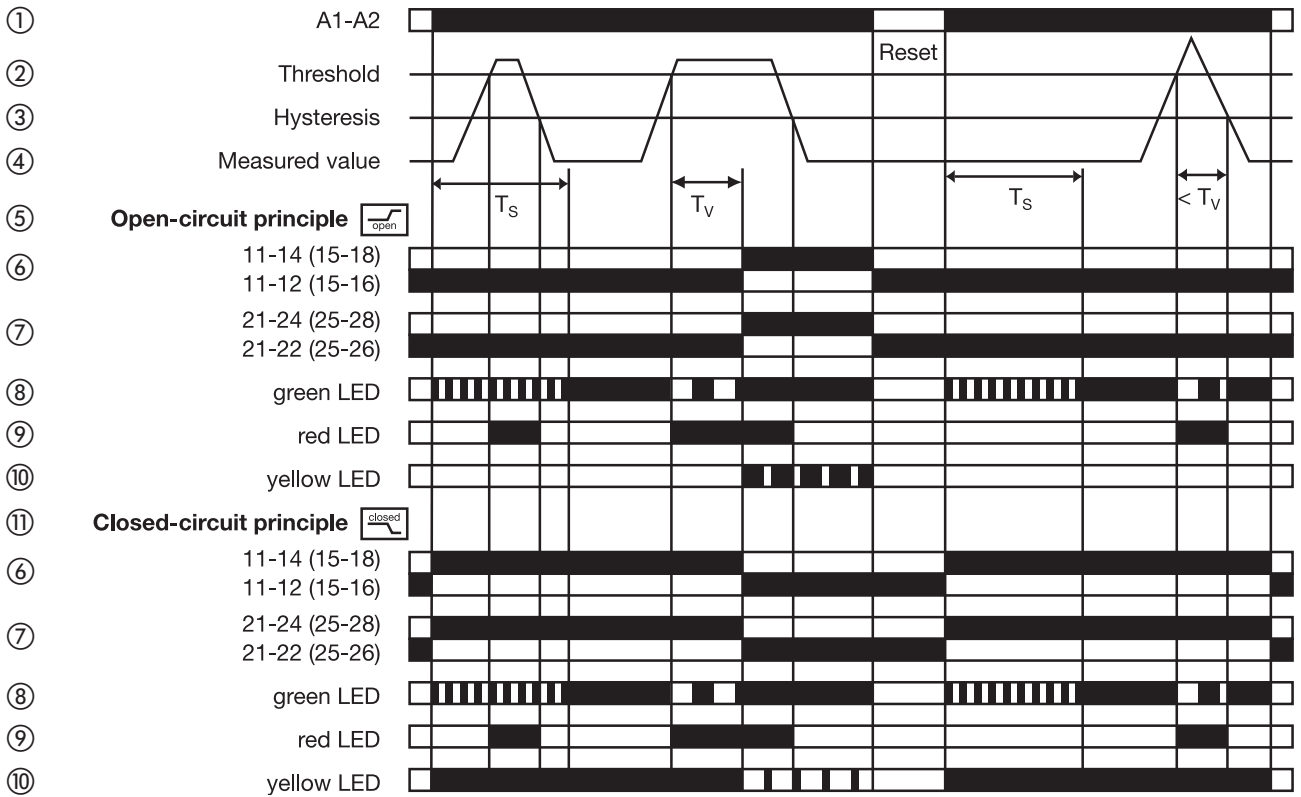



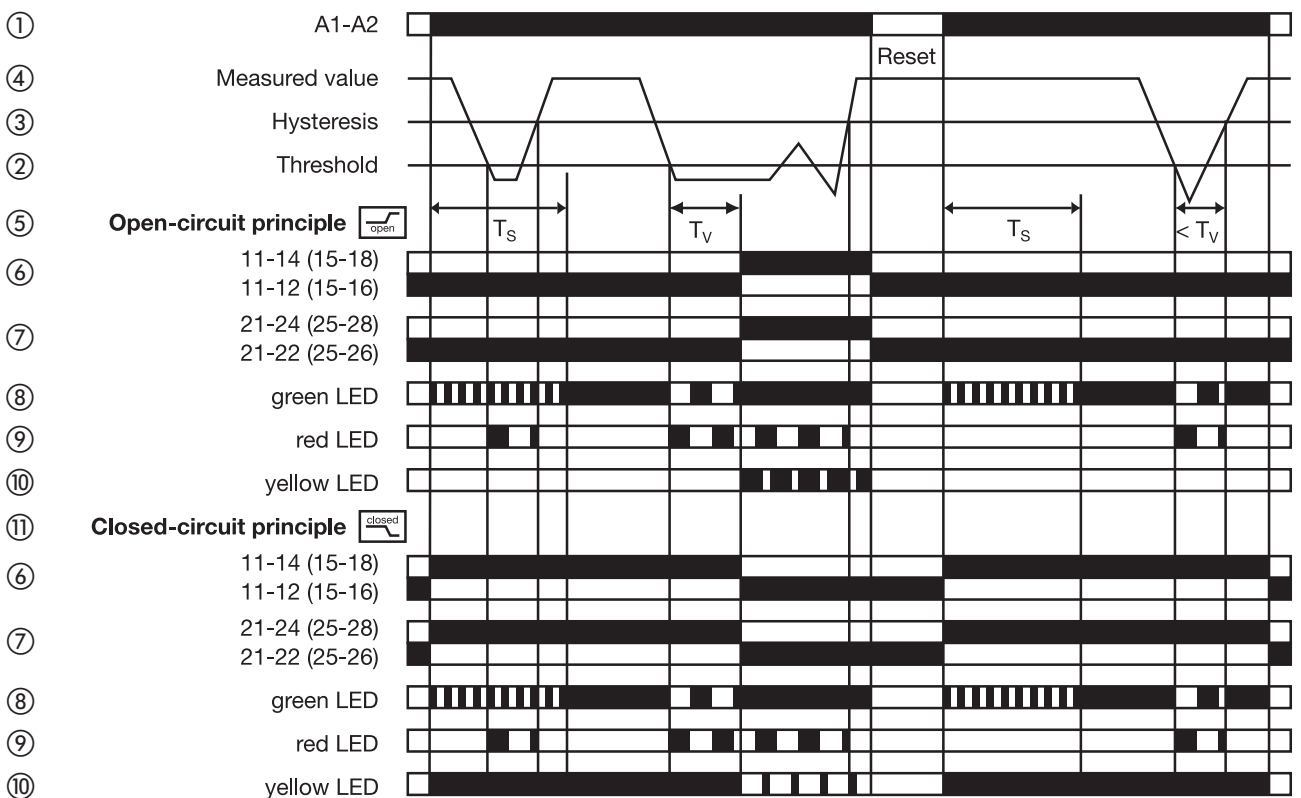

2CDC 252 214 F0205



VIII Undercurrent monitoring with latching









2CDC 252 215 F0205

Arbeitsweise





Die Stromüberwachungsrelais CM-SRS.M können in einphasigen AC- oder DC-Netzen je nach Konfiguration zur Über-  oder Unterstromüberwachung  eingesetzt werden. Der zu überwachende Strom (Messwert) wird dazu an den Klemmen B1/ B2/B3-C eingespeist. Die Geräte arbeiten je nach Einstellung nach dem Arbeits-  oder Ruhestromprinzip .



Über- bzw. unterschreitet der Messwert den eingestellten Schwellwert vor Ablauf der eingestellten Einschaltverzögerung T_S behalten die Ausgangsrelais ihren aktuellen Zustand bei. Über- bzw. unterschreitet der Messwert den eingestellten Schwellwert nach Ablauf von T_S , wird die Auslöseverzögerung T_V gestartet. Befindet sich der Messwert nach Ablauf von T_V noch über bzw. unter dem Schwellwert minus bzw. plus der eingestellten Hysterese, ziehen die Ausgangsrelais an  / fallen die Ausgangsrelais ab .

Unter- bzw. überschreitet der Messwert den Schwellwert minus bzw. plus die eingestellte Hysterese, fallen die Ausgangsrelais ab  / ziehen die Ausgangsrelais an , sofern die Speicherung nicht aktiviert ist . Bei eingeschalteter Speicherung  bleiben die Ausgangsrelais angezogen  und fallen erst ab, wenn die Steuerspeisespannung unterbrochen wird / bleiben die Ausgangsrelais abgefallen  und ziehen erst wieder an, wenn die Steuerspeisespannung aus- und wieder eingeschaltet wird = Reset.





Die Hysterese ist in einem Bereich von 3-30 % des Schwellwerts einstellbar.



Funktionsdiagramme







- V Überstromüberwachung ohne Speicherung 
- VI Unterstromüberwachung ohne Speicherung 
- VII Überstromüberwachung mit Speicherung 
- VIII Unterstromüberwachung mit Speicherung 

- ① Steuerspeisespannung
- ② Schwellwert
- ③ Hysterese
- ④ Messwert
- ⑤ Arbeitsstromprinzip 
- ⑥ Ausgangsrelais 1
- ⑦ Ausgangsrelais 2
- ⑧ LED grün
- ⑨ LED rot
- ⑩ LED gelb
- ⑪ Ruhestromprinzip 

Operating principle





Depending on the configuration, the current monitoring relays CM-SRS.M can be used for over-  or undercurrent monitoring  in single-phase AC or DC systems. The current to be monitored (measured value) is applied to terminals B1/B2/B3-C. Open  or closed-circuit principle  are selectable.



If the measured value exceeds drops below the adjusted threshold value before the set start-up delay T_S is complete, the output relays do not change their state. If the measured value exceeds drops below the adjusted threshold value when T_S is complete, the tripping delay T_V starts. If T_V is complete and the measured value is still exceeding or below the threshold value minus / plus the set hysteresis, the output relays energize  / de-energize .

If the measured value exceeds or drops below the threshold value plus / minus the set hysteresis and the latching function is not activated , the output relays de-energize  / energize . With activated latching function , the output relays remain energized  and de-energize only, when control supply voltage is interrupted / the output relays remain de-energized  and energize only, when control supply voltage is switched off and then again switched on = Reset.





The hysteresis is adjustable within a range of 3-30 % of the threshold value.



Function diagrams







- V Overcurrent monitoring without latching 
- VI Undercurrent monitoring without latching 
- VII Overcurrent monitoring with latching 
- VIII Undercurrent monitoring with latching 

- ① Control supply voltage
- ② Threshold value
- ③ Hysteresis
- ④ Measured value
- ⑤ Open-circuit principle 
- ⑥ Output relay 1
- ⑦ Output relay 2
- ⑧ green LED
- ⑨ red LED
- ⑩ yellow LED
- ⑪ Closed-circuit principle 

Principe de fonctionnement





Selon la configuration, les contrôleurs de courant CM-SRS.M peuvent être utilisés pour surveiller la sur-  ou sous-intensité  dans des réseaux AC ou DC monophasés. Le courant de mesure (valeur mesurée) est appliqué aux bornes B1/B2/B3-C. Les relais fonctionnent en logique positive  ou négative , selon le réglage.



Si la valeur mesurée dépasse ou chute en dessous de la valeur de seuil ajustée avant la fin de la temporisation de démarrage T_S les relais de sortie gardent leur position. Si la valeur mesurée dépasse ou chute en dessous de la valeur de seuil ajustée après la fin de la temporisation de démarrage T_S , la temporisation de déclenchement T_V commence. Les relais de sortie s'activent  / se désactivent , si, après la fin de T_V , la valeur mesurée se trouve encore en dessus ou en dessous de la valeur de seuil moins ou plus l'hystérésis ajustée.

Si la valeur mesurée dépasse ou chute en dessous de la valeur de seuil plus ou moins l'hystérésis ajustée, les relais de sortie se désactivent  / s'activent , pourvu que la mémorisation ne soit pas activée . Avec la mémorisation activée , les relais de sortie restent activés  et se désactivent seulement quand la tension d'alimentation de commande est coupée / les relais de sortie restent au repos  et s'activent seulement quand la tension d'alimentation de commande est coupée et puis branchée de nouveau = Remise à zéro.





L'hystérésis est ajustable dans une gamme de 3-30 % de la valeur du seuil.



Diagrammes de fonctionnement







- V Contrôle de surintensité sans mémorisation 
- VI Contrôle de sous-intensité sans mémorisation 
- VII Contrôle de surintensité avec mémorisation 
- VIII Contrôle de sous-intensité avec mémorisation 

- ① Tension d'alimentation de commande
- ② Valeur de seuil
- ③ Hystérésis
- ④ Valeur mesurée
- ⑤ Fonctionnement en logique positive 
- ⑥ Relais de sortie 1
- ⑦ Relais de sortie 2
- ⑧ LED verte
- ⑨ LED rouge
- ⑩ LED jaune
- ⑪ Fonctionnement en logique négative 

Funcionamiento





Dependiendo de la configuración, el relé de control de intensidad CM-SRS.M puede utilizarse para sobre-  o subintensidad  en redes monofásicas de CA o de CC. La corriente de medida (valor medido) se aplica a los terminales B1/B2/B3-C. Principio de circuito abierto  o cerrado  seleccionable.



Si el valor medido, excede o cae por debajo del valor umbral ajustado antes de que el retardo de arranque T_S se haya completado, los relés de salida no cambiarán de estado. El retardo de disparo T_V empieza si el valor medido excede o cae por debajo del valor umbral cuando T_S se ha completado. Si T_V se ha completado y el valor medido sigue por encima o por debajo del valor umbral ajustado, menos/más el valor ajustado de histéresis, los relés de salida se energizan  / des-energizan .

Si el valor medido excede o cae por debajo del valor umbral ajustado y la función de retención no está activada , los relés de salida se des-energizan  / energizan . Con la función de retención activada , los relés de salida se mantienen energizados  y des-energizan sólo cuando se interrumpe la alimentación / los relés de salida se mantienen des-energizados  y se energizan sólo cuando se desconecta la tensión de alimentación de mando y se vuelve a conectar = Reset.





La histéresis es ajustable en el rango de 3-30% del valor umbral.



Diagramas de funcionamiento







- V Control de sobrecorriente sin función de retención 
- VI Control de subcorriente sin función de retención 
- VII Control de sobrecorriente con función de retención 
- VIII Control de subcorriente con función de retención 

- ① Tensión de alimentación de mando
- ② Valor umbral
- ③ Hystéresis
- ④ Valor medido
- ⑤ Principio de circuito abierto 
- ⑥ Relé de salida 1
- ⑦ Relé de salida 2
- ⑧ LED verde
- ⑨ LED rojo
- ⑩ LED amarillo
- ⑪ Principio de circuito cerrado 

Funzionamento





A seconda della configurazione, i relè di controllo di corrente CM-SRS.M possono essere utilizzati per controllare sovra-  o sottocorrente  in sistemi CA/CC monofasi. La corrente di misura (valore misurato) viene applicata ai morsetti B1/B2/B3-C. Gli apparecchi lavorano secondo il principio di funzionamento normalmente aperto  o normalmente chiuso .



Se il valore misurato aumenta o diminuisce oltre il valore di soglia impostato prima che il ritardo di inserzione T_S impostato sia trascorso, i relè di uscita non cambiano stato. Se il valore misurato aumenta o diminuisce oltre il valore di soglia impostato dopo che è trascorso il tempo T_S , il ritardo di intervento T_V inizia. Se, dopo che è trascorso il tempo T_V , il valore misurato è ancora superiore o inferiore al valore di soglia meno o più l'isteresi impostata, i relè di uscita si eccitano  / diseccitano .

Se il valore misurato diminuisce o aumenta oltre il valore di soglia meno o più l'isteresi impostata, i relè di uscita si diseccitano  / eccitano , in quanto che la memorizzazione non sia attivata . Con la memorizzazione attivata , i relè di uscita rimangono eccitati  e si diseccitano solo se la tensione di comando viene interrotta / i relè di uscita rimangono diseccitati  e si eccitano solo se la tensione di comando viene disinserita e poi di nuovo inserita = Ripristino.



L'isteresi è regolabile in un campo di 3-30 % del valore di soglia.



Diagrammi di funzionamento



- V Controllo di sovracorrente senza memorizzazione 
- VI Controllo di sottocorrente senza memorizzazione 
- VII Controllo di sovracorrente con memorizzazione 
- VIII Controllo di sottocorrente con memorizzazione 







- ① Tensione di comando
- ② Valore di soglia
- ③ Isteresi
- ④ Valore misurato
- ⑤ Funzionamento normalmente aperto 
- ⑥ Relè di uscita 1
- ⑦ Relè di uscita 2
- ⑧ LED verde
- ⑨ LED rosso
- ⑩ LED giallo
- ⑪ Funzionamento normalmente chiuso 

Принцип работы

В зависимости от конфигурации реле контроля тока CM-SRS.M может использоваться для контроля перегрузки по току  или пониженного тока  в однофазных сетях постоянного или переменного тока.

Контролируемый ток (измеряемое значение) подается на клеммы B1/B2/B3-C. Можно выбрать принцип разомкнутой  или замкнутой  цепи.

Если измеряемое значение превысит или соответственно упадет ниже заданного порогового значения до того, как окончится отсчет времени задержки включения T_S , то выходные реле не изменят своего состояния. Если измеряемое значение превысит или соответственно упадет ниже заданного порогового значения после того, как окончится отсчет времени задержки включения T_S , начнется отсчет времени задержки срабатывания реле T_V . Если отсчет времени T_V закончился, а измеряемое значение все еще превышает/остаётся ниже порогового значения за минусом/плюсом заданного гистерезиса, то выходные реле возбуждаются  /обесточиваются .

Если затем измеряемое значение возвращается в заданные пределы, т.е. превышает минимальный порог/опускается ниже максимального порога на величину гистерезиса и функция памяти не включена , то выходные реле обесточиваются /возбуждаются . При включенной функции памяти  выходные реле остаются под напряжением  и обесточиваются только когда прерывается электропитание/ выходные реле остаются обесточенными  и возбуждаются только когда питающее напряжение отключается, а затем снова включается = Сброс.

Гистерезис регулируется в диапазоне 3-30% порогового значения.



Function diagrams

V Контроль перегрузки по току без запоминания 





VI Контроль пониженного тока без запоминания 



VII Контроль перегрузки по току с запоминанием 





VIII Контроль пониженного тока с запоминанием 

- ① Питающее напряжение
- ② Пороговое значение
- ③ Гистерезис
- ④ Измеряемое значение
- ⑤ Принцип разомкнутой цепи 
- ⑥ Выходное реле 1
- ⑦ Выходное реле 2
- ⑧ Зеленый светодиод
- ⑨ Красный светодиод
- ⑩ Желтый светодиод
- ⑪ Принцип замкнутой цепи 

动作原则





根据设定, 电流监视器 CM-SRS.M 可用作单相 AC 或 DC 系统的过  或欠  电流监视。被监视电流 (测量值) 连接于端子 B1/B2/B3-C。开路  或闭路  原则可选。

如果在设定的启动延时 T_S 之前, 被监视值超出设定的阈值, 输出继电器并不改变其状态。当设定的启动延时 T_S 结束, 如果被监视值超出设定的阈值, 响应延时 T_V 开始计时。当 T_V 计时结束, 被监视值仍然超出设定阈值减去响应的固定迟滞, 输出继电器动作  / 复位 。

如果测量值回复到设定阈值加上迟滞, 且故障存储功能不被激活 , 输出继电器复位  / 动作 。当故障存储功能  被激活时, 输出继电器保持动作 。仅当供电电压断开时才复位 / 输出继电器保持复位, 仅当供电电压关断且重新接通 = 重置时才动作。

迟滞调节范围为阈值的 3-30 %。

功能图

- V 过电流监视, 不带故障存储 
- VI 欠电流监视, 不带故障存储 
- VII 过电流监视, 带故障存储 
- VIII 欠电流监视, 带故障存储 

- ① 供电电压 A1-A2
- ② 阈值
- ③ 迟滞
- ④ 测量值
- ⑤ 开路原则 
- ⑥ 输出继电器 1
- ⑦ 输出继电器 2
- ⑧ 绿色 LED
- ⑨ 红色 LED
- ⑩ 黄色 LED
- ⑪ 闭路原则 