

en

IHP 1C 18 mm:
CCT15854

IHP+ 1C 18 mm:
CCT15837



Schneider
Electric

Discover your IHP

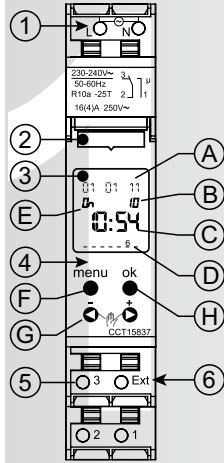

- (A) Date
- (B) Seconds
- (C) Hours: minutes
- (D) Day (Day 1 = Monday by default)
- (E) Display of output contact state
- (F) "menu": selection of operating mode
- (G) "-", "+": navigation and parameter setting keys
- (H) "ok": flashing information validation key

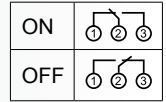

Reset by pressing simultaneously the 4 keys "+", "-", "menu" and "ok", i.e. (F), (G) and (H)

- ① 230 V AC power supply, +10%, -15%, 50/60 Hz
- ② Programming key connector
- ③ LCD screen
- ④ Transparent cover
- ⑤ Output contacts
- ⑥ External control input (CCT15837)

Cable

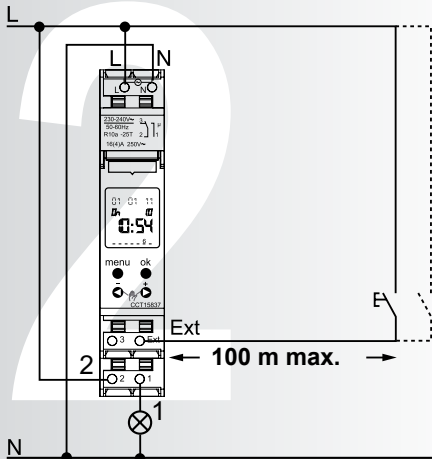

Note:

The external input operating mode is defined at the level of Chapter 7, "Adapt configuration".

Configure

At power up or after performing a Reset (see "Discover" chapter):

- With the "-" and "+" keys.
- Choose the language (French, English, etc.).
- Choose "PROGRAM" to delete or retain the program existing in the product.
- Set the date, year, month, day and time.
- Choose the summer/winter time change parameters.

When this phase is completed, the "NO MAINS" message is displayed; you must programme your IHP.

If you do not agree with the flashing value or word: scroll the display with the "-" and "+" keys.

To confirm the flashing value or word: confirm with "ok".

If you are lost: press "menu" to return to the previous mode without saving the last change.

If you actuate no key during 2 minutes: you are automatically returned to Auto mode without saving.

Zone	Summer time	Winter time	Comments
EUROPE	Last Sunday of March at 2 am	Last Sunday of October at 3 am	
GB/IRL/P	Last Sunday of March at 1 am	Last Sunday of October at 2 am	Great Britain - Portugal
FIN/GR/TR	Last Sunday of March at 3 am	Last Sunday of October at 4 am	Finland - Greece - Turkey
CDN	First Sunday of April at 2 am	Last Sunday of October at 3 am	Canada
FREE RULE	According to choice	According to choice	Choice of month, week, day (Monday, Tuesday, etc.) and time
FIX DATE	According to choice	According to choice	Choice of month, date (01, 02, etc.) and time
NONE	-	-	

Programme your IHP

The IHP allows you to programme 3 types of controls: switching (On/Off), pulses (CCT15837) and cycles (CCT15837)

To create an operating period: programme **On** switching then **Off** switching. The "COPY" function allows you to replicate on the other days the switching, pulse or a cycle currently being created and save memory space (creation of a "block"). Access "PROGRAM" mode by pressing the "menu" key; you then have 5 possibilities:

- **"NEW"**: to build the program and enter it in memory.
- **"CHECK"**: to view the program.
- **"MODIFY"**: to make changes in the program already in memory. If the transition selected to be modified is repeated on other days of the week, the product prompts "MODIFY BLOCK"; this function proposes performing modification of all identical transitions (type and time).
- **"DELETE"**: to delete all or part of the program (the date, time and choice of language are retained). If the transition selected to be deleted is repeated on other days of the week, the product prompts "DELETE BLOCK"; this function proposes performing deletion of all identical transitions (type and time).
- **"END"**: to exit "PROGRAM" mode.

Date / Time

Modify the time, date, summer/winter time, day of the week, time format or date format.

Press "menu", and access "TIME/DATE" mode via the "+" key:

- Change the time, minutes, and date.
- Choose summer/winter time (see table in the "Configure" chapter).
- Define the first day of the week (e.g. Monday for Europe).
- Modify the date format, "FORM DATE":
 - D / M / Y
 - M / D / Y
 - Y / M / D.
- Modify time format, "FORM TIME":
 - display on 24h
 - display on 12h.

Manual mode, "MANUAL"

In this mode you can:

- Programme periods "PERM ON", "PERM OFF", "OVERRIDE".
- Program a holiday period, "HOLIDAY" (temporarily cancel On periods by setting the dates and times of start and end of absence).
- On ref. CCT15837 you can also:
 - change, for an adjustable period, the operation (channel **On** or **Off**) from the current time, "TIMER";
 - use the product in random mode "RANDOM" (to perform presence simulation).

To perform one of these operations you must: press "menu", and access "MANUAL" mode via the "+" key.

- "HOLIDAY": possibility of having four different types of operation in this Holiday mode:
 - "ON": output activated
 - "OFF": output deactivated
 - "RANDOM 1": random operation in a fixed On range
 - "RANDOM 2": On operation in a range for which the start and end are random.

After defining the type of operation, enter the start and end of absence dates.

- "TIMER": to define the state and duration of the override.

- "RANDOM":
 - "RANDOM 1"
 - "RANDOM 2"

Its operation is identical to the Holiday mode, but with no time limits.

Manual and permanent forced ON/OFF "Ⓜ" "Ⓞ"

- **Activate temporary ON or temporary OFF** (until next switching) by pressing the two "Ⓜ" "Ⓞ" keys simultaneously for less than 2 s; the output contact changes state:
 - the IHP indicates by "MANUAL" the new output contact state.
 - return to automatic mode by pressing briefly the same two keys for less than 2 s.

- **Go to permanent ON or permanent OFF** by pressing the two "Ⓜ" "Ⓞ" keys simultaneously for more than 2 s: with each press for more than 2 s, the output contact changes state:
 - the IHP indicates the new output contact state by "PERM".
 - return to automatic mode by pressing briefly the same two keys for less than 2 s.

The IHP also allows external override control by an external switch or push button, cabled to the Ext terminal (CCT15837):

permanent **On** or **Off** override by external input (switch) takes priority over the product's forced ON/OFF function.

For setting the external input, see "Adapt the configuration".

Electronic key (ref. CCT15861)

- For easier programming of your IHP you have an electronic key, supplied with the IHP CCT15837, optional for the IHP CCT15854.

Before inserting your electronic key, place the product in "Auto" mode.

Insert your electronic key in its slot ②, and a specific menu appears:

- "COPY KEY → TSWI": to copy the program from the key to your IHP.
- "COPY TSWI → KEY": to copy the program from the IHP to the key.
- "RUN KEY": to have the IHP operate with the programming stored in the key's memory, without program transfer.
- "CHECK KEY": to read the content of the electronic key, each programming step is then displayed by pressing the "+" key; a press on "ok" takes you back to the main menu.
- "END": to remove the key.

A key programming kit (ref. CCT15860) comprising a PC/Key interface, a cord, a key and a programming software allows you to programme your key directly from a PC.

Load table

- Acceptable output contact power:

- resistive loads:
 - I max. = 16 A - 250 V AC (cos φ = 1),
 - I min. = 10 mA - 230 V AC, 100 mA - 12 V AC/DC
- motors: 1000 W.

Type of lighting	Max. power per contact
Resistive load	16 A
Cos φ = 0.6	4 A
230 V incandescent lamp	1000 W
230 V halogen lamp	1000 W
Fluorescent tube	1000 VA
Parallel compensated fluorescent tube, max. 120 W (18 µF)	3 x 40 W (4,7 µF) - 2 x 58 W (7 µF) - 1 x 100 W (18 µF)
CFL compact fluorescent lamp, max. 40 W	5 x 7 W - 3 x 11 W - 2 x 15 W - 2 x 20 W - 1 x 23 W
LED up to 2 W	10 W
LED between 2 W and 8 W	25 W
Compact fluorescent lamp with electronic ballast	22 x 7 W - 18 x 11 W - 16 x 15 W - 16 x 20 W - 14 x 23 W

For other applications, relay with a contactor.

Adapt the configuration, "CONFIG"

Press "menu", and access "CONFIG" mode via the "+" key.

In this "CONFIG" mode you can:

- **View the counter indicating the operating time of the "OPERATING HOUR" output** and, if you want, perform resetting of this counter.
 - "OPERATING HOUR":
 - "SHOW HOUR": counter reading
 - "DELETE": counter resetting.

■ **Define the type of external input, "EXT INPUT"** (this choice must correspond to the part cabled on the product) and its operating mode (CCT15837); there are three possible choices:

- NOT ACTIVE
- BUTTON
- SWITCH

When the type has been defined, you must define the operating mode:

- for the button:
 - OVERRIDE: temporary override control until next switching
 - TIMER: one press initiates a time delay for a given period; this time delay can take place in **On** mode or **Off** mode at the output level.
- for the switch:
 - Permanent **On**
 - Permanent **Off**.

For both options, the switch is open in normal operation and its closing results in an **On** or an **Off** at output.

- **Modify the "PIN" code** (default code 0000):
 - NO PIN
 - WITH PIN.

If you have forgotten the PIN code, see the 9-digit number on the side of the product, and enter the 4 digits in ABCD position: xAxBxCxDx

Example: No. 123456789: the PIN code is 2468.

- **Modify the language, "LANGUAGE"**.

- **Return to the product initialization phase "FACTORY SETTINGS"** ("Configure" chapter 3).

- Access the product reference "INFO".

Programme pulses and cycles (CCT15837)

- Access "PULSE" mode by pressing the "menu" key, "PROGRAM", "ok", "NEW", "ok" access "PULSE" mode with the "+" key.
 - Choose "ON" or "OFF" mode.
 - Set the time.
 - Set the pulse length (PULSE LENGTH).

- Access "CYCLE" mode by pressing the "menu" key, "PROGRAM", "ok", "NEW", "ok" access "CYCLE" mode with the "+" key.
 - Set the start of cycle time.
 - Set the pulse length (PULSE LENGTH).
 - Set the pause duration (PAUSE).
 - Set the end of cycle time.

Characteristics

- Power consumption: max. 0.4 W.
- Memory: 56 switching operations, 84 (CCT15837).
- Min. time between 2 switching operations: 1 minute.
- Working temperature: -25°C ... +55°C (prefer installation in the least hot area of the enclosure).
- Protection class: II in accordance with EN 60730 (product installed in enclosure).
- Degree of protection: IP20 in accordance with EN 60529.
- Operating precision: $\leq \pm 0.5$ s/day at 25°C.
- Power reserve: 10 years (lithium battery).
- Pollution degree: 2.
- Device of 1 BSTU type in accordance with IEC/EN 60730-2-7 or EN 60730-1.
- Connectors:
 - cables, 2 x 0.5 to 2.5 mm²
 - stripping length: 9 mm max.
- Size (9 mm modules): 2 modules.
- Weight: 90 g.